



#### STANDARD EQUIPMENT FOR BASE MACHINE

- Air cleaner, double element with dust indicator
- Alternator, 35 ampere/24V
- Batteries, 140 Ah/2 x 12V
- Blower cooling fan
- Decelerator pedal
- Engine hood
- Fenders
- Lighting system, (includes 2 front, 1 rear)
- Mono-lever steering
- Muffler with curved exhaust pipe
- Radiator guard door, flat
- Radiator reserve tank
- Rear cover
- ROPS mounting brackets
- Starting motor, 7.5 kW/24V
- Seat, adjustable
- Track roller guard, end sections
- Track shoe assembly
  - Sealed and lubricated track
    - 510 mm 20" single grouser shoe
- Underguards, oil pan and transmission
- Wet, multiple-disc steering clutch/brake



#### OPTIONAL EQUIPMENT

- Air conditioner
- Backup alarm
- Cab
- Cab accessories
  - Cup holder
  - Rear view mirror
- Cooling fan, reversible
- Electronic instrument monitor panel
- Engine side covers, gull-wing
- Front pull hook
- Heater and defroster
- Hitch type drawbar
- High mount foot rests
- Hydraulics for ripper
- Hydraulics for tilt dozer
- Intake pipe with precleaner
- Light working, cab additional
- Locks, filler caps and covers
- Pressure check ports for power train
- Radiator core protective grid
- Rigid type drawbar
- ROPS canopy
- ROPS canopy with sweep
- Seat belt, retractable
- Suspension seat, with high-back
- Suspension seat, reclining with fabric material (cab only)
- Track roller guard, full length
- Underguard, heavy-duty
- Vandalism protection cover for instrument panel
- Water separator

#### ROPS CANOPY

- Additional weight 420 kg 930 lb
- Meets ISO 3471 and SAE J1040 APR88, ROPS standards, and ISO 3449 FOPS standard.
- Roof dimensions:
  - Length: 1830 mm 6'0"
  - Width: 1600 mm 5'3"
  - Height from operator compartment floor: 1700 mm 5'7"

#### STEEL CAB

- Additional weight 285 kg 630 lb
- All-weather, enclosed pressurized cab
- Dimensions:
  - Length: 1765 mm 5'9"
  - Width: 1720 mm 5'8"
  - Height: 1625 mm 5'4"
  - Height from floor to ceiling: 1515 mm 5'0"

#### MULTI-SHANK RIPPER

- Additional weight (including hydraulic control unit): 1680 kg 3,700 lb
- Beam length: 2170 mm 7'1"
- Maximum digging depth: 595 mm 1'11"
- Maximum lift above ground: 640 mm 2'1"

#### ROPS CANOPY FOR CAB

- Additional weight 340 kg 750 lb
- Meets ISO 3471 and SAE J1040 APR88, ROPS standards, and ISO 3449 FOPS standard.
- Roof dimensions:
  - Length: 1270 mm 4'2"
  - Width: 1490 mm 4'11"
  - Height from operator compartment floor: 1705 mm 5'7"

#### SHOES

Shoe	Additional weight	Ground contact area
560 mm 22.0" single-grouser shoe	+120 kg +260 lb	33380 cm <sup>2</sup> 5,170 in <sup>2</sup>
610 mm 24.0" single-grouser shoe	+230 kg +510 lb	36360 cm <sup>2</sup> 5,640 in <sup>2</sup>
660 mm 26.0" single-grouser shoe	+360 kg +790 lb	39340 cm <sup>2</sup> 6,100 in <sup>2</sup>

www.komatsu.com

Printed in Japan 201005 IPAD (05)

# KOMATSU

CEN00163-02

Materials and specifications are subject to change without notice.  
KOMATSU is a trademark of Komatsu Ltd. Japan.

**HORSEPOWER**  
Net: 149 kW 200 HP @ 1950 rpm

**OPERATING WEIGHT**  
20670 kg 45,570 lb

# KOMATSU

## D85ESS-2A

WITH STEERING CLUTCH/BRAKE SYSTEM

**D**  
**85ESS**

CRAWLER DOZER



Photo may include optional equipment.



# WALK-AROUND

**The Komatsu S6D125E-2 diesel engine** provides an output of **149 kW** 200 HP with excellent productivity.

Left hand **joystick** controls all tractor motion. Right hand joystick controls all blade movements.

**Gull-wing** engine side covers for easy and safer servicing. (optional)

High capacity **Straight tilt dozer** combined the highest power in its class with outstanding productivity.

**Blade tilt lines** completely protected.

**Komatsu Torqflow transmission** offers single lever control of speed (3 forward and 3 reverse) and directional changes.

Forward mounted **pivot shafts** isolate final drives from blade loads.

**Electronic monitoring system** prevents minor problems from developing into major ones. (optional)

**Optional hexagonal, low noise cab** with viscous damping mounts provides unsurpassed operator comfort and visibility.



**Wet, multiple-disc brakes** eliminates brake-band adjustments for maintenance-free operation.

**Bolt-on segmented sprocket teeth** for easy in-the-field replacement

**Modular power train** for increased serviceability and durability.

Photo may include optional equipment.

**HORSEPOWER**  
Net: 149 kW 200 HP @ 1950 rpm  
**OPERATING WEIGHT**  
20670 kg 45,570 lb  
**BLADE CAPACITY (SAE)**  
Straight Tilt Dozer:  
4.4 m<sup>3</sup> 5.8 yd<sup>3</sup>  
Angle Dozer:  
3.4 m<sup>3</sup> 4.4 yd<sup>3</sup>



# OPERATOR'S COMPARTMENT

All steering, direction, and speed changes are made by a left-hand single joystick control. If the operator wants to move the machine forward and to the left, he simply moves the joystick forward and to the left. If he desires a gear change, he merely twists his wrist. The machine responds to the movement of the lever providing the operator with the feeling of natural control with Komatsu's joystick.

### Low-noise design

For smoother riding comfort, power train components and hydraulic control valves are mounted to the frame with rubber pads to soften vibration and shut out noise. Since the D85ESS employs joysticks, the walk-through operator compartment is uncluttered for smooth entry and exit. An adjustable seat with backrest is standard equipment.

### Three-stage height adjustable armrests

Three-stage height adjustable armrests and relocated fuel control lever provide comfortable operation and increased leg space.



### Easy-to-operate work equipment control lever

With the Closed-center Load Sensing (CLSS) hydraulic system, blade lever stroke is directly proportional with blade speed, regardless of the load and travel speed. This results in superb, fine controllability.

### Benefits of CLSS

- More precise and responsive operation due to the pressure compensation valve.
- Reduced fuel consumption by discharging only the required amount of oil from the pump.
- The work equipment moves smoothly for operations such as side-cutting even when priority is given to steering.

CLSS for D85ESS-2A

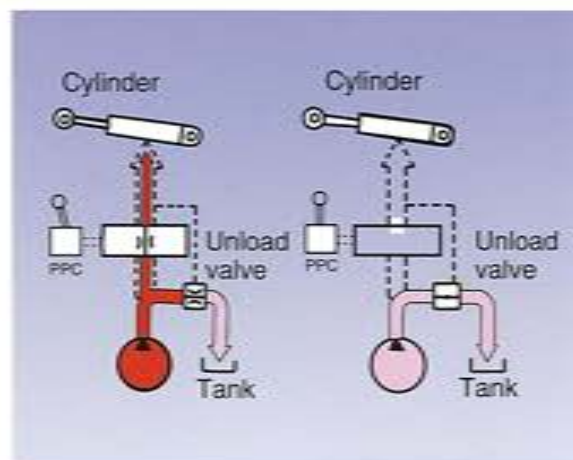

### Electronic monitoring system (optional)

An electronic monitoring system prevents minor problems from developing into major ones. All meters and gauges are controlled by a microcomputer, which provides a wide indication range for an easier, more precise reading.



# RELIABILITY FEATURES

### Field-proven engine

Powerful S6D125E-2 diesel engine provides a massive output of 149 kW 200 HP. The engine power is transmitted smoothly to the final drives via a high-efficiency torque converter.

### Modular designed power train units

The modular design allows easy removal and installation of any individual unit for shorter downtime.

### Flat bottom frame

A flat bottom frame, the monocoque track frames and forward-mounted pivot shafts provide good maneuverability in muddy terrain by preventing mud from building up under the frame.

### Sturdy design

Because fewer components mean greater reliability, we've designed a simple hull frame made of a thick, single plate. Track frames have a large-section construction for maximum rigidity. Even the box-section construction of the blade back beam is reinforced, all with durability in mind.

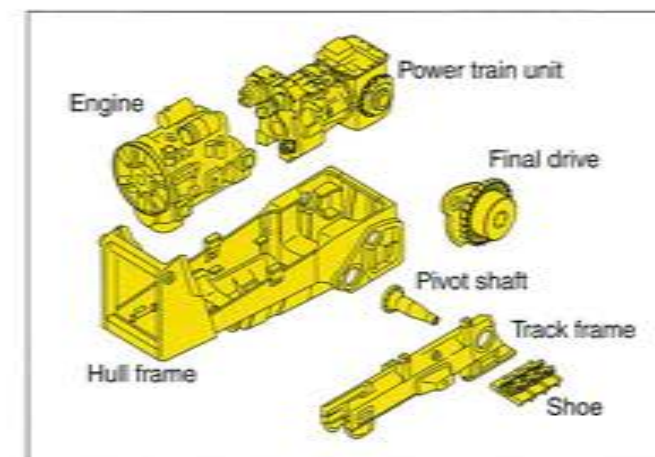

### Tough undercarriage

Large-diameter bushings, increased track link heights, and improved oil-seals help to increase undercarriage durability. Serviceability has also been improved with the addition of remote greasing of the equalizer bar center pin.

### Low drive and long track undercarriage

Komatsu's design is extraordinarily tough and offers excellent grading ability and stability.

# EASY MAINTENANCE

### Wet, multiple-disc brakes

Eliminate brake-band adjustments for maintenance-free operation.

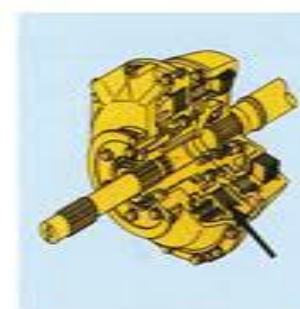

### Oil pressure check ports (optional)

Oil pressure check ports for the power train are centralized on the right hand side of the operator platform for easy access.



### Coolant reservoir

A radiator coolant reservoir makes it easier to check the coolant level and eliminates frequent refilling.



### Gull-wing engine side covers (optional)

A gas-spring cylinder opens the gull-wing engine side covers widely, allowing the engine and auxiliary components to be easily checked.





# SPECIFICATIONS

## ENGINE

Model ..... Komatsu S6D125E-2  
 Type ..... 4-stroke cycle, water-cooled, direct injection  
 Aspiration ..... Turbocharged  
 Number of cylinders ..... 6  
 Bore x stroke ..... 125 mm x 150 mm 4.92" x 5.91"  
 Piston displacement ..... 11.04 ltr 674 in<sup>3</sup>  
 Governor ..... All-speed, mechanical  
 Horsepower  
 ISO 9249 / SAE J1349 ..... Net 149kW 200HP  
 Rated rpm ..... 1950rpm  
 Fan drive type ..... Mechanical  
 Lubrication system  
 Method ..... Gear pump, forced lubrication  
 Filter ..... Full-flow  
 Net maximum torque ..... 981 N·m 100 kg·m 723 lb ft @ 1200 rpm

## TORQFLOW TRANSMISSION

Komatsu's TORQFLOW transmission consists of a water-cooled, 3-element, 1-stage, 1-phase torque converter and a planetary gear, multiple-disc clutch transmission which is hydraulically actuated and force-lubricated for optimum heat dissipation. Joystick control of gears (3 forward and 3 reverse) and directional steering changes. Gearshift lock lever and neutral safety switch prevent machine from accidental starts.

Travel speed	Forward	Reverse
1st	0-3.9 km/h 0-2.4 mph	0-5.0 km/h 0-3.1 mph
2nd	0-6.8 km/h 0-4.2 mph	0-8.6 km/h 0-5.3 mph
3rd	0-10.6 km/h 0-6.6 mph	0-13.4 km/h 0-8.3 mph

## FINAL DRIVES

Double-reduction final drives of spur gear and planetary gears to minimize transmission of shocks to power train components. Segmented sprocket are bolt-on for easy in-the-field replacement.

## STEERING SYSTEM

Joystick controls for all directional movements. Pushing the joystick forward results in forward machine travel, while pulling it rearward reverses the machine. Simply tilt the joystick to the left to make a left turn. Tilt it to the right for a right turn.  
 Wet, multiple-disc steering clutches are hydraulically loaded and hydraulically released. Wet, multiple-disc brakes are spring-actuated and hydraulically released.  
 Steering brakes also function as service and parking brakes.  
 Minimum turning radius\* ..... 3.4 m 11'2"  
 \*As measured by track marks on ground.

## UNDERCARRIAGE

Suspension ..... Oscillation with equalizer bar and forward mounted pivot shafts  
 Track roller frame ..... Monocoque, large section, durable construction  
 Track shoes ..... Lubricated tracks. Unique dust seals for preventing entry of foreign abrasives into pin-to-bushing clearances for extended service.  
 Track tension is easily adjusted with a grease gun.  
 Number of carrier rollers (each side) ..... 2  
 Number of track rollers (each side) ..... 8  
 Ground contact area ..... 30400 cm<sup>2</sup> 4,710 in<sup>2</sup>  
 Ground pressure ..... 50.0 kPa 0.50 kg/cm<sup>2</sup> 7.25 psi

## COOLANT AND LUBRICANT CAPACITY (REFILL)

Coolant ..... 52 ltr 13.7 U.S. gal  
 Fuel tank ..... 406 ltr 107.3 U.S. gal  
 Engine oil ..... 38 ltr 10.0 U.S. gal  
 Damper ..... 1.7 ltr 0.4 U.S. gal  
 Transmission, bevel gear, and steering system ..... 48 ltr 12.7 U.S. gal  
 Final drive (each side) ..... 27 ltr 7.1 U.S. gal

## OPERATING WEIGHT

Tractor weight:  
 Including rated capacity of lubricant, coolant, full fuel tank, operator and standard equipment ..... 15420 kg 34,000 lb

Operating weight:  
 Including angle dozer, multi-shank ripper, FRP canopy(optional), operator, standard equipment, and rated capacity of lubricants, coolant, and full fuel tank ..... 20670 kg 45,570 lb

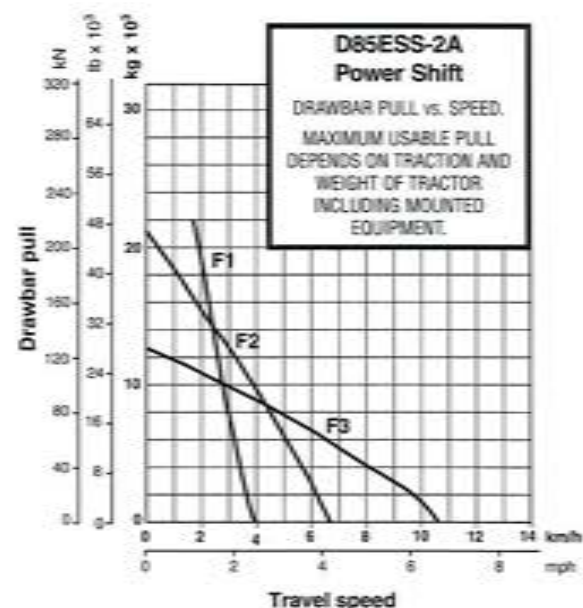

## HYDRAULIC SYSTEM

Closed-center load sensing system (CLSS) designed for precise and responsive control, and for efficient simultaneous operation.

Hydraulic control units:  
 All spool control valves externally mounted beside the hydraulic tank.  
 Type of pump: ..... Gear pump

Capacity (discharge flow at rated engine rpm): ..... 180 ltr/min 47.6 U.S. gal/min  
 Relief valve setting ..... 20.6 MPa 210 kgf/cm<sup>2</sup> 2,990 psi

Hydraulic cylinders ..... Double-acting, piston

	Number of cylinders	Bore
Blade lift	2	95 mm 3.74"
Blade tilt	1	140 mm 5.51"
Ripper lift	1	140 mm 5.51"

Control valves:  
 Spool control valve for semi-U tilt dozer and straight tilt dozer:  
 Positions: Blade lift ..... Raise, hold, lower, and float  
 Blade tilt ..... Right, hold, and left  
 Spool control valve for angle dozer:  
 Positions: Blade lift ..... Raise, hold, lower, and float  
 Additional control valve for multi-shank ripper:  
 Positions: Ripper lift ..... Raise, hold, and lower

Hydraulic oil capacity (refilling):  
 Straight tilt dozer ..... 55.0 ltr 14.5 U.S. gal  
 Angle tilt dozer ..... 55.0 ltr 14.5 U.S. gal  
 Multi-shank ripper ..... 55.0 ltr 14.5 U.S. gal

## DOZER EQUIPMENT

Use of high tensile strength steel in moldboard for strengthened blade construction.

	Overall length with dozer	Blade capacity*	Blade length x height	Maximum lift above ground	Maximum drop below ground	Maximum tilt adjustment	Angling angle	Additional weight	
								Dozer equipment	Hydraulic control unit
AngleDozer	5930 mm 19'5"	3.4 m <sup>3</sup> 4.4 yd <sup>3</sup>	4370 mm x 1070 mm 14'4" x 3'6"	1255 mm 4'1"	485 mm 1'7"	400 mm 1'4"	25 degree	2890 kg 6,370 lb	540 kg 1,190 lb
Straight Tilt Dozer	5615 mm 18'5"	4.4 m <sup>3</sup> 5.8 yd <sup>3</sup>	3620 mm x 1295 mm 11'11" x 4'3"	1070 mm 3'6"	590 mm 1'11"	460 mm 1'6"	--	2220 kg 4,890 lb	590 kg 1,300 lb
Semi-U Tilt Dozer	5770 mm 18'11"	6.8 m <sup>3</sup> 8.9 yd <sup>3</sup>	3640 mm x 1565 mm 11'11" x 5'2"	1070 mm 3'6"	590 mm 1'11"	460 mm 1'6"	--	2520 kg 5,560 lb	590 kg 1,300 lb

Remarks:  
 \* Blade capacities are based on the SAE recommendation practice J1265.

## DIMENSIONS

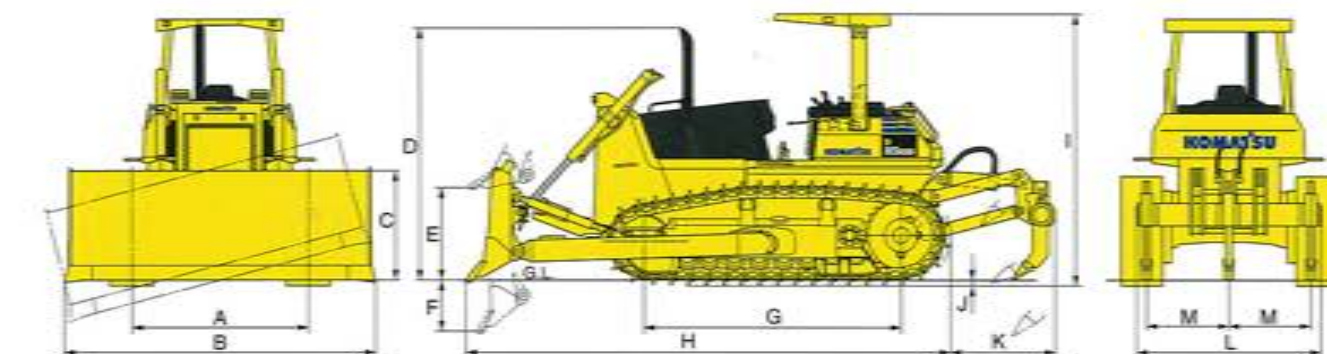

Ground clearance ..... 400 mm 1'4"

Dimension with straight tilt dozer and multi-shank ripper.

A	2050 mm 6'9"	H	5615 mm 18'5"
B	3620 mm 11'11"	I	3160 mm 10'4"
C	1295 mm 4'3"	J	65 mm 2'6"
D	2980 mm 9'9"	K	1220 mm 4'0"
E	1070 mm 3'6"	L	2170 mm 7'1"
F	590 mm 1'11"	M	950 mm 3'1"
G	2980 mm 9'9"		